

FTE7000A-DWDM Optical Time Domain Reflectometer



Features:

- Tunable OTDR with 89 C Band Wavelengths
- Tunable CW/Pulsed Laser Source w/ 50/100GHz Spacing
- Touch Screen Operation
- Fib-R-View Auto Pass/Fail/Centering Fiber Inspector
- Fib-R-Map Comprehensive Event Analysis
- 89 Channels (17-61) on the ITU Grid
- 35 dB OTDR Dynamic Range
- 12 Hour Li-ion Battery Pack
- Bidirectional Analysis
- Bluetooth Android Tablet Operation
- Report Generating Software Included

Applications

- Fiber Characterization in DWDM Networks
- Verify ROADM Channel Routing
- Wavelength Provisioning
- Test through OADMs
- In service DWDM Network Trouble shooting
- Test through MUX/DMUX Channels
- CBH Antenna Feeds

Maintain and Troubleshoot DWDM Networks Easily and Cost Effectively

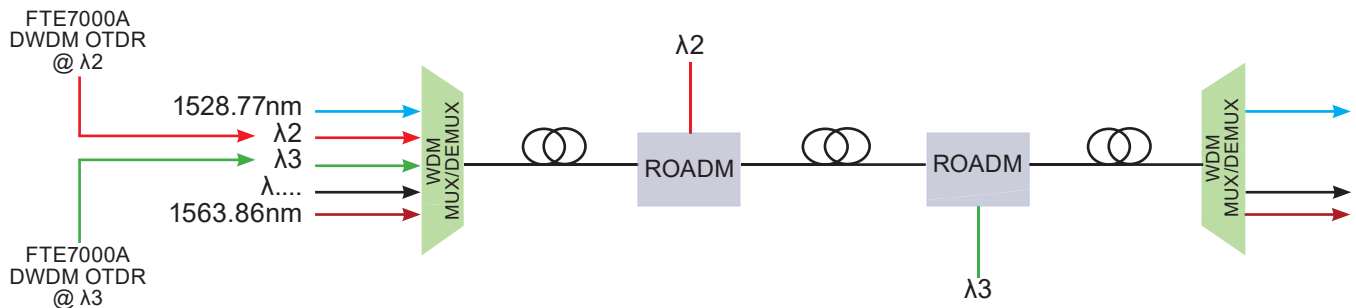

Made In the USA

Terahertz Technologies Inc.

FTE7000A-DWDM *Optical Time Domain Reflectometer*

The FTE7000A-DWDM is a Tunable DWDM OTDR with 89 wavelengths from the C Band spectrum. These 89 wavelengths are available in a single hand-held, tunable OTDR. The FTE7000A-DWDM also operates as Tunable Light source with 8 - 14dBm output. Use the FTE7000A-DWDM for commissioning and troubleshooting DWDM Metro Ethernet Networks.

89 DWDM Wavelengths in one Hand Held Tunable OTDR

These OTDRs offer features and options that include auto pass/fail connector end face testing with video scope and probe, broadband power meter, CW source and VFL.

OTDR -

One-Touch auto test will test up to 89 DWDM wavelengths
Automatic Pass/Fail Summary with Fib-R-Map Trace Analysis
Test through MUX - DEMUX units at up to 89 channels on the ITU-T grid

Tunable Laser Source -

Use the FTE7000A-DWDM as a Tunable Laser Source

Cert-Soft Software -

Complete professional network documentation

Video Scope -

Auto pass/fail analysis
Automatic image centering



Made In the USA

Terahertz Technologies Inc.

FTE7000A-DWDM *Optical Time Domain Reflectometer*

OTDR Specifications

Standard Wavelengths	1528.77-1563.86nm @ 0.4 and 0.8nm Spacing
Dynamic Range	35 dB
Pulse Width	5 - 20,000 ns
Units of Measurement	km, kf, mi
Event Dead zone	1m
Attenuation Dead Zone	4m
Data Points	up to 120,000
Resolution	.125 - 32m
Distance Uncertainty	$\pm(0.75m + 0.005\% \times \text{distance} + \text{sampling resolution})$
Full Scale Distance Range	1-240km SM
Typical Real-time Refresh Rate	2 Hz
Group Index of Refraction (GIR)	1.024 - 2.048
Linearity	$\pm .05 \text{ dB/dB}$
Memory Capacity (Internal)	~1000

TTI reserves the right to change specifications without notice.

TLS Specifications

Frequency Range	FTE-6000 C 192 - 196 THz (1529-1563nm)
Accuracy	1.5 GHz
Line Width	1 MHz
Side Mode Suppression Ration	45 dB
Output Power Range	+8 dBm to +14 dBm (C Band)
Power Setting Resolution	0.01 dB
Power Variation over Wavelength Range	$\pm 0.5 \text{ dB}$
Minimum Channel Spacing	50 GHz (0.4nm)
Fiber Type	9/125 μm
\pm Relative Intensity Noise	-140 dB/Hz

TTI reserves the right to change specifications without notice.



Made In the USA

Terahertz Technologies Inc.

FTE7000A-DWDM *Optical Time Domain Reflectometer*

General Specifications

Graphical Display	4 in Color Touch Screen
Power Supply / Charger	Input 100-240V 50-60Hz, 0.6A / Output 15V, 1.2A
Battery / Operating Time	Rechargeable Li-Ion / 10 hour
Storage Temperature	-20 to 60 C
Operating Temperature Range	-10 to 40 C
Dimensions (w/out rubber boot)	7.75" L x 4.5" W x 2.25" H (197mm L x 114mm W x 57mm H)
Weight	1.7 lbs
Communications / Ports	Bluetooth / USB-PC
Connector Styles	FC, SC Interchangeable
Accessories Provided	Universal Power Adapter w/US, UK, Continental Europe, and Australian Plugs, Interchangeable FC and SC Adapters, Windows/Telcordia SR4731 Software, Rubber Boot and Manual on CD, 2 stylus

TTI reserves the right to change specifications without notice.

***FTE7000A-DWDM OTDRs Test The C Band
Optical Spectrum in OTDR Mode And May Be
Used As C Band Tunable Laser Source***

Ordering Information

FTE-7000A-DWDM	C Band DWDM Tunable OTDR/Laser Source 1528-77nm - 1563-86nm
FTE-DWDM-K	FTE7000A-DWDM OTDR/Laser Source and FTE8100-C Mini OSA
VIS300	Video Probe for FTE7500 and FTE7000 Series

Terahertz Technologies Inc.



Made In the USA

TTI makes every effort to insure all statements and information for the products referred to in this document are accurate and reliable. TTI can not accept any responsibility for errors, omissions or miss statements, nor can they accept responsibility for any actions taken based on the information demonstrated herein. TTI reserves the right to make changes of any kind to the product referred to in this document without prior notice.
© 1/2015 Terahertz Technologies Inc.